

MAXAM 24 – Mobile tiered seating

Maxam 24 is a mobile tiered seating unit that provides a simple to use flexible seating system perfect for use in school halls and sports centres. The product can be set alongside installations of Maxam bleacher seating or used as a standalone item in a variety of layouts. The seating units are easy to deploy and can be efficiently moved to storage locations via integrated casters.

APPLICATIONS

Maxam 24 is suitable for a wide range of seating applications including schools, sports halls, team benches and swimming pools.

FEATURES

- Rolls away for efficient storage
- Simple to use and maintain
- Features the Courtside polymer bench seat

SPECIFICATIONS

- 24 seats – HSM 24 and 18 seats – HSM 24A
- Row rise 245mm
- Row depth 660mm
- Aisle 914mm (HSM 24A only)
- Width 2740mm
- Stored depth 1165mm
- Stored height 2360mm

ACCESSORIES

- Side safety rails
- Intermediate steps – For HSM24A
- Hot dipped galvanised finish for wet applications
- Upholstered benches on request

FINISHES

- Seats: Courtside – 15 standard colours
- Metalwork: Satin Black EPC
- Beams: Galvanised
- Decks: Grey polydeck

TECHNICAL

For all technical details, please see the reverse side of this specification sheet.
CAD drawings are available on request.



husseyseatway
PUBLIC SEATING SYSTEMS



Hussey Seatway Ltd, 3 Centurion Way, Crusader Park, Warminster, Wiltshire, BA12 8BT U.K.

Tel: +44 (0)1985 847200 Fax: +44 (0)1985 847300 www.husseyseatway.com sales@husseyseatway.com

MAXAM 24 - ROLL-AWAY

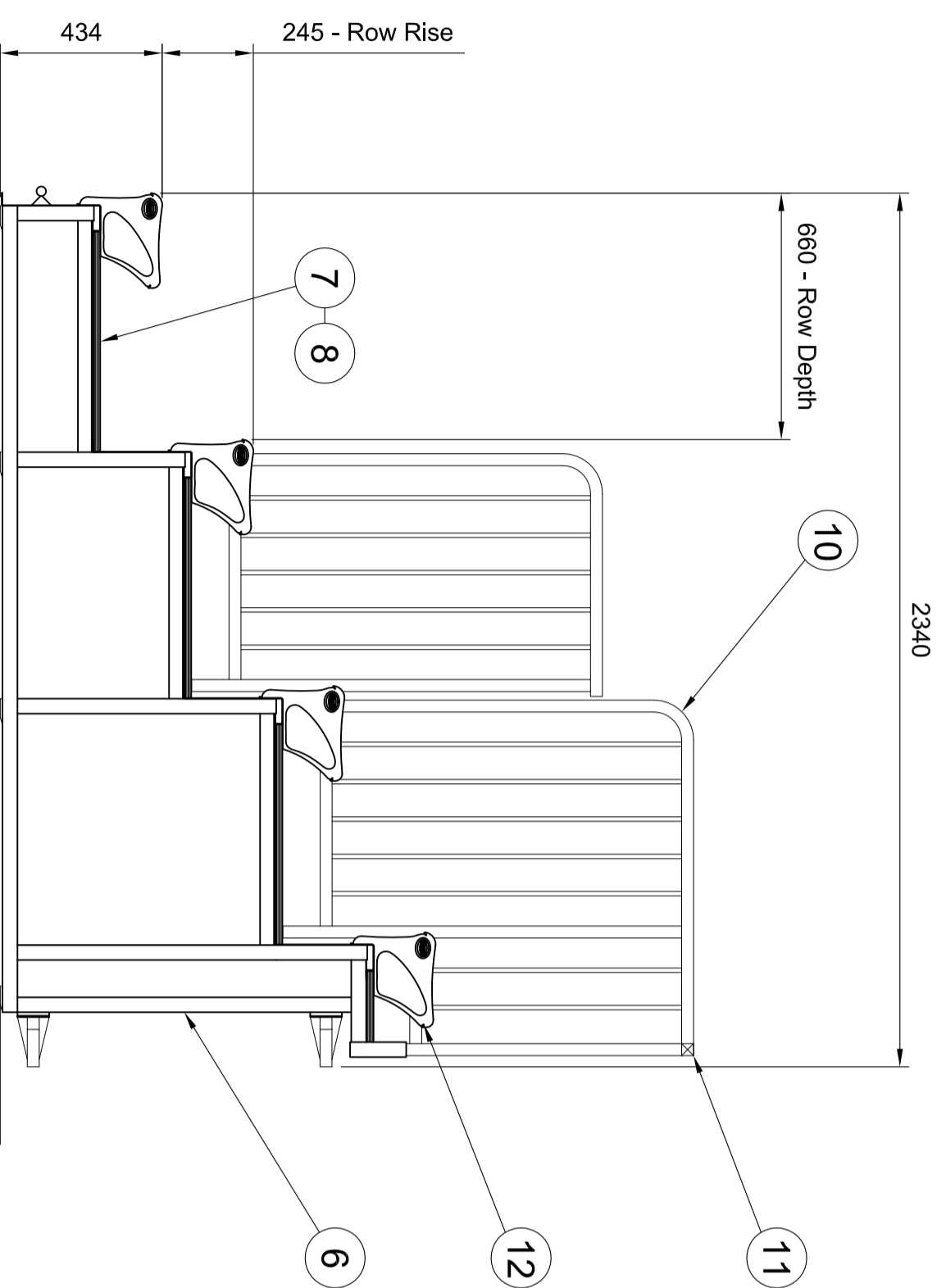

SIDE ELEVATION - Maxam 24 (HSM24)

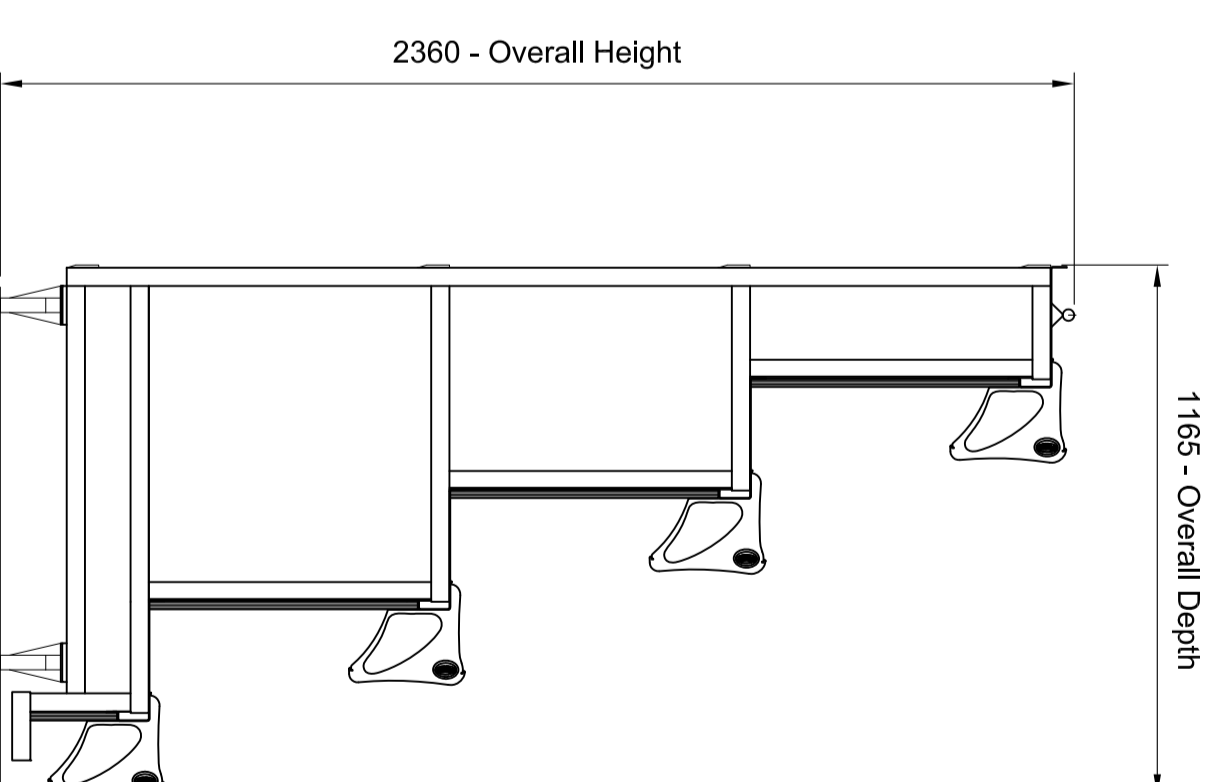

SIDE ELEVATION
(Unit in Store Position)

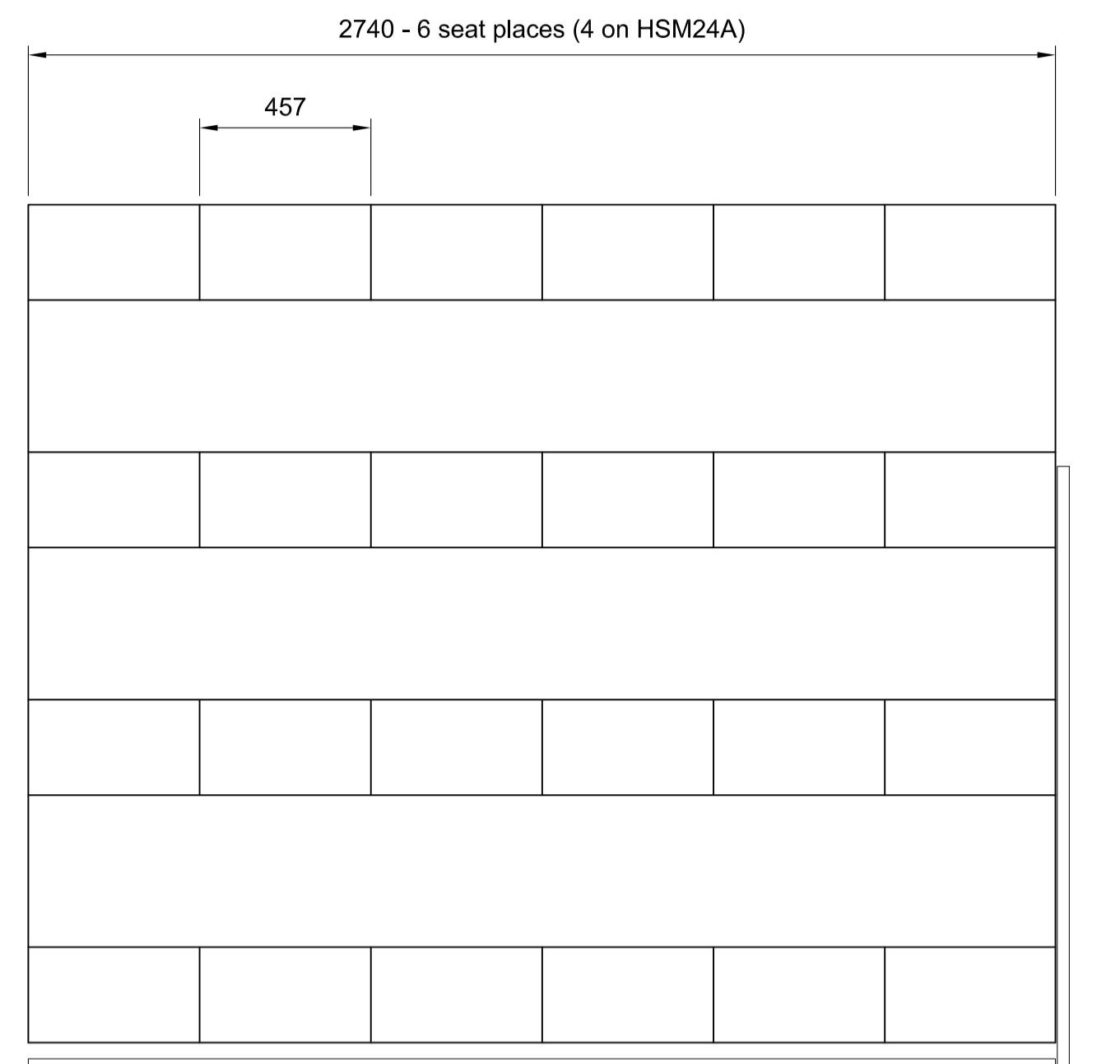

PLAN VIEW

SALES SPECIFICATION	
Ref. Description	
1 PRODUCT IDENTIFICATION:	HSM24 - 24 seats HSM24A - 18 seats c/w centre aisle.
2 ROW RISE:	245 mm.
3 ROW DEPTH:	660 mm.
4 NUMBER OF ROWS:	4 No.
5 REAR PLATFORM:	None.
6 PLATFORM STRUCTURE:	SATIN BLACK STANDARD.
7 PLATFORM DECKING:	18 mm THICKNESS.
8 DECKING FINISH:	Grey PVC (Polydeck)
9 INTERMEDIATE STEPS:	3 no. on HSM24A
10 SIDE RAILS:	ACCESSORY - Specify number required.
11 REAR RAILS:	INCLUDED (Standard Equipment)
12 SEAT TYPE:	Maxam COURTSIDE
13 SEAT CENTRES:	457 mm. nominal
TOTAL SEAT QUANTITY:	HSM24 = 24 seats HSM24A = 18 seats

GENERAL TOLERANCE
± 1.0 mm

HUSSEY **husseyseatway**
PUBLIC SEATING SYSTEMS

THIS DRAWING IS THE PROPERTY AND
COPYRIGHT OF HUSSEY SEATWAY LTD.
COPYING OR REPRODUCTION WITHOUT
WRITTEN PERMISSION IS PROHIBITED. © 2003

Tel: +44 (0)1985 847200
Fax: +44 (0)1985 847300
Email: info@husseyseatway.com

Item/Ref. Quantity Title/Name designation, material, dimension etc. Article No./Reference

SALES DRAWING

MAXAM 24
Roll-away Seating Unit.

Metric Version

A1 Scale
1:12