

# Monet – Fixed Chair

The Monet is an elegant fixed auditorium chair. The contoured plush foam seat and back design of the Monet chair makes it an excellent choice for venues in which extended seating periods are expected. As standard the chair features an outer backrest panel and wooden armrests providing a luxury feel to the product.

## APPLICATIONS

A stylish and well designed shared stanchion chair, suited to theatre, conference and cultural facilities.

## FEATURES

- Fully upholstered seat, upholstered back with outer wood panel.
- Sprung inner seat core with cold moulded polyurethane foam.
- Armrests – Wood type as standard.
- Wood aisle end panels
- Seat centres from 500mm-550mm.
- Self-tipping design.
- Available on rows with an 800mm row depth.

## OPTIONS

- Seat numbers and row letters
- Show wood seat panels
- Fully upholstered backrest
- Upholstered armrests and aisle end panels
- Dampened seat tipping
- Wood intermediate stanchions
- 45° seat return position

## FINISHES

- Fabric from the Xtreme range by Camira
- Customers own choice of fabric can be specified
- Metalwork: Satin black powder coat
- Armrests: Wood or upholstered

## TECHNICAL

For all technical details, please see the reverse side of this specification sheet.

CAD drawings are available on request.



**husseyseatway**  
PUBLIC SEATING SYSTEMS

Hussey Seatway Ltd, 3 Centurion Way, Crusader Park, Warminster, Wiltshire, BA12 8BT U.K.

Tel: +44 (0)1985 847200 Fax: +44 (0)1985 847300 [www.husseyseatway.com](http://www.husseyseatway.com) sales@husseyseatway.com



Seat Centre (SC)	19 3/4" - 21 3/4" [500mm - 550mm]
Min Row Depth	31 1/2" [800mm]

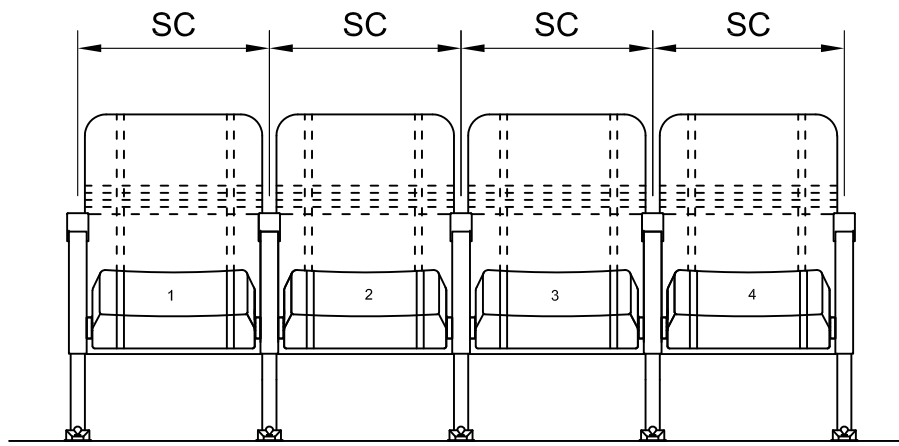
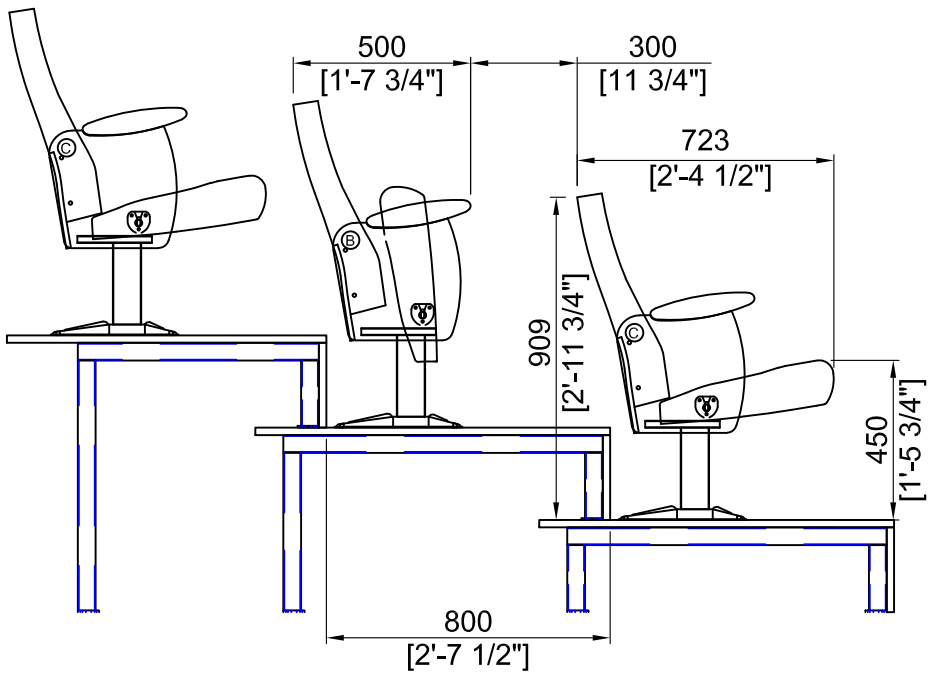
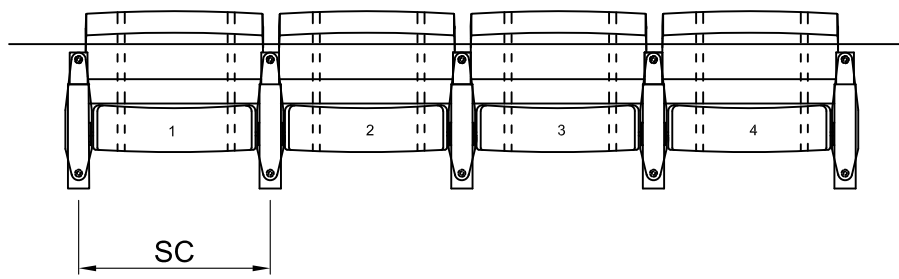

GENERAL TOLERANCE  
± 1 mm

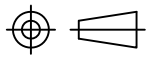

THIS DRAWING IS THE PROPERTY AND COPYRIGHT OF HUSSEY SEATWAY LTD. COPYING OR REPRODUCTION WITHOUT WRITTEN PERMISSION IS PROHIBITED. © 2020

Tel: +44 (0)1985 847200  
Fax: +44 (0)1985 847300  
Email: info@husseyseatway.com

Itemref	Quantity	Title/Name, designation, material, dimension etc	Article No./Reference
---------	----------	--	-----------------------

Monet Fixed Chair

PRODUCT SPECIFICATION LAYOUT	Imperial Version	A3 Scale 1:15
------------------------------	------------------	------------------